



B34S Series Regulator

Medium Duty Commercial and Industrial Regulator

Appropriate for many commercial and industrial uses such as gas engines, burners, furnaces and boilers. The rapid response of the B34S is particularly well-suited for mid-range applications where quick on/off loads cause shock problems.

MODEL DESCRIPTION

- » The B34S is a spring-loaded, self operated regulator available with or without internal relief. It combines the B31 8" diaphragm case with the B34 valve assembly for an economical solution to mid-range commercial and industrial applications. Among its attributes are an adjustable loading ring for controlled boost at high flows, precision breather opening to ensure proper stability under all conditions, and, in the R model, a high capacity internal relief valve. All critical parts are either steel or aluminum to ensure reliability
- » B34SN – The B34SN is a spring-loaded, self-operated regulator with no internal relief. This regulator can be used on mid-range applications where an internal relief or other type of over-pressure protection device is not required

- » B34SR – The B34SR is the internal relief version of the B34S series. This model features an internal relief valve with a 1" vent

FEATURES

- » Interchangeable brass orifice
- » 27 in² of diaphragm area
- » Molded diaphragm consisting of Buna-N and nylon
- » Upper diaphragm plate of plated steel
- » Stainless steel lever pin
- » Zinc with dichromate plated steel lever
- » One piece molded Buna-N valve seat
- » Alodined aluminum valve stem
- » Delrin® vent valve with Buna-N seat
- » Spring-loaded internal relief valve assembly

- » Vent Sizes: 1/4", 3/8", 3/4", and 1"
- » Stainless steel vent screen
- » Die cast aluminum seal cap
- » Field interchangeable adjustment spring
- » Controlled size breather orifice eliminates pulsation and provides normal action at low flows
- » Wide range of valve body sizes including NPT and flange connections

BENEFITS

- » Economical
- » Protects equipment from shock damage
- » Space saving design
- » Commercial performance in a compact size

B34S SERIES COMMERCIAL REGULATOR

SHIPPING WEIGHT

Four regulators per box, screwed body. Box weight: 100 lbs.
Two regulators per box, flanged body. Box weight: 70 lbs.

B34S DIMENSIONS (INCHES)

Valve Body	A	B	C	D	E	F	G	R
1-1/4, 1-1/2, or 2 NPT	5-1/4	2-7/8	6	7-13/16	3-1/4	4-7/8	4-1/2	2-1/4
2 Flanged	10	5	6	7-13/16	3-1/4	4-7/8	5-1/2	3-1/4
3 Flanged	10	5	6	7-13/16	3-1/4	4-7/8	5-1/2	3-1/4

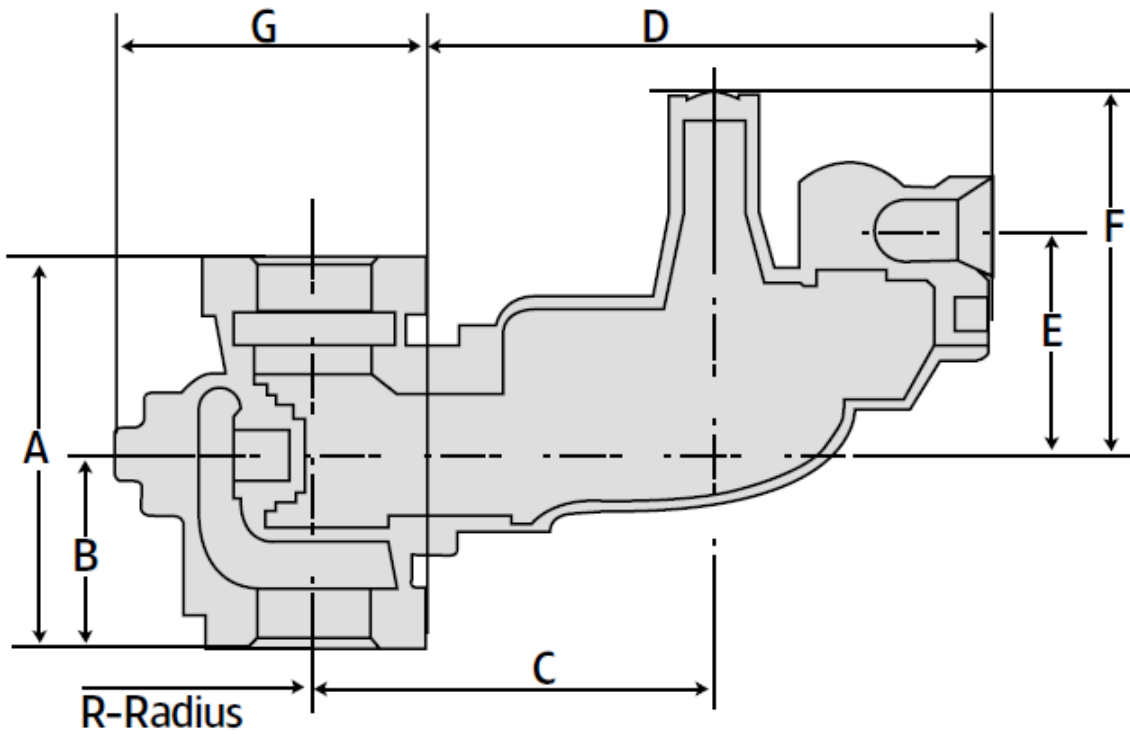

VALVE BODY SIZES (INCHES)

Inlet	Outlet	Screwed	Flanged
1-1/4	1-1/4	X	---
1-1/4	1-1/2	X	---
1-1/4	2	X	---
1-1/2	1-1/2	X	---
1-1/2	2	X	---
2	2	X	X
3	3	---	X

SPRING DATA, SPRING COLOR OUTLET PRESSURE RANGE*

Models B34S N & R

Colors	Part Number	Outlet Pressure Range inches w.c.
Brown	762111	3.5 - 5.0
Dark green	762117	4.5 - 6.5
Light green	762119	5.5 - 7.5
Black	762123	6.0 - 9.0
Blue	762127	8.5 - 12.5
Silver	762129	11.0 - 17.0

Models B34S NHP and RHP

Colors	Part Number	Outlet Pressure Range PSIG
Red/gray	762025	.75 - 1.1
Yellow	762131	1.2 - 1.5
Red	762135	1.5 - 1.9
White	762137	1.75 - 2.5

*Ranges are approximations, please contact Itron to obtain the best spring for your application.

ORIFICE DATA, WIDE OPEN FLOW COEFFICIENTS AND MAXIMUM PRESSURES

Orifice Size (inches)	K-Factor	Maximum Operating Inlet (PSIG)	Maximum Emergency Inlet Pressure (PSIG)	Maximum Emergency Outlet Pressure PSIG		
		All Deliveries All Models	All Deliveries All Models	All Deliveries All Models No Damage	Inches Deliveries All Models Containment	PSIG Deliveries All Models Containment
1/4	125	125	150	60	18	60
1/4 x 3/8	125	125	150			
3/8	290	125	150			
3/8 x 1/2	305	60	100			
1/2	500	60	100			
1/2 x 5/8	530	25	100			
5/8	700	25	60			
5/8 x 3/4	750	15	60			
3/4	900	15	60			
3/4 x 7/8	950	10	40			
7/8	1050	10	40			
7/8 x 1	1100	10	40			

OPERATING TEMPERATURE RANGE

- -20°F to 150°F
- Silicone valve seats available for applications below -20°F

ADDITIONAL SPECIFICATIONS

Available Vent Sizes:	1/4", 3/8", 3/4", and 1"
Loading Ring Position:	R & N Models for <1 PSIG set point: 15°, > 1 PSIG set point: 0°
Other Available Options:	Seal wire to indicate unapproved tampering
	1/8" pipe plug tap on upstream side of valve body
	Teflon valve body gasket

COMPLIANCE

The B34SR (internal relief model) compliance with ANSI Z21.80, Line Pressure Regulators

Model B34SR us with a 1" vent connection is compliant with ANSI Z21.80 in the configurations noted and shown in the following tables:

With inlet pressures up to 2 PSIG, the B34SR is compliant in any configuration.

With inlet pressures up to 5 PSIG

Orifice Size (inches)	Set Point	Maximum Vent Line Length (ft.)*	Number of Elbows**
1/4	Up to 1 PSIG	50	4 or less
1/4" x 3/8"	Up to 1 PSIG	50	4 or less
3/8"	Up to 14" w.c.	50	4 or less
3/8" x 1/2"	Up to 14" w.c.	50	4 or less
1/2"	Up to 14" w.c.	20	4 or less
1/2" x 5/8"	Up to 14" w.c.	20	4 or less
5/8"	Up to 14" w.c.	No vent line	No vent line
5/8" x 3/4"	Up to 14" w.c.	No vent line	No vent line
3/4"	Up to 14" w.c.	No vent line	No vent line

* Clean 1" black steel pipe

** For each elbow greater than 4 elbows, subtract 2.6 ft. from the maximum vent line length.

With inlet pressures up to 10 PSIG

Orifice Size (inches)	Set Point	Maximum Vent Line Length (ft.)*	Number of Elbows**
1/4	Up to 1 PSIG	50	4 or less
1/4" x 3/8"	Up to 1 PSIG	50	4 or less
3/8"	Up to 14" w.c.	25	4 or less
3/8" x 1/2"	Up to 14" w.c.	25	4 or less
1/2"	Up to 14" w.c.	No vent line	No vent line

CONSTRUCTION

Itron takes pride in delivering products with the utmost concern for safety, quality, and customer satisfaction.

Construction material

Valve body	High tensile strength cast iron (ASTM A-126, Class A)
Orifice	Brass
Valve seat	Buna-N or silicone (for temperatures below -20°F)
Valve stem	Alodined aluminum
Lever pin	Stainless steel
Lever	Zinc and dichromate plated steel
Stem Guide	Stainless steel
Upper diaphragm plate	Zinc and dichromate plated steel
Lower diaphragm plate	Die cast aluminum
Diaphragm	Buna-N and nylon
Vent valve/seat	Delrin/Buna-N
Vent screen	Stainless steel
Adjustment ferrule	Delrin or aluminum (HP)
Seal cap	Die cast aluminum
Diaphragm case	Die cast aluminum

CORRECTION FACTORS FOR NON-NATURAL GAS APPLICATIONS

The B34S may be used to control gases other than natural gas. To determine the capacity for gases other than natural gas, multiply the values within the capacity tables by a correction factor. The table below lists the correction factors for some of the more common gases:

Gas Type	Specific Gravity	Correction Factor (CF)
Air	1.00	0.77
Butane	2.01	0.55
Carbon Dioxide (Dry)	1.52	0.63
Carbon Monoxide (Dry)	0.97	0.79
Natural Gas	0.60	1.00
Nitrogen	0.97	0.79
Propane	1.53	0.63
Propane-Air-Mix	1.20	0.71

To calculate the correction factor for gases not listed in the table above, use the gases' specific gravity and insert it in the formula listed below:

$$\text{Correction Factor (CF)} = \sqrt{\frac{SG_1}{SG_2}}$$

Where:

SG₁ = Specific gravity of the gas in which the capacity is published.

SG₂ = Specific gravity of the gas to be controlled.

Wide Open Flow Calculations

For wide-open orifice flow calculations use the following equations:

$$\text{For } \frac{P_1}{P_2} < 1.89 \text{ use: } Q = K\sqrt{P_2(P_1 - P_2)} \quad \text{For } \frac{P_1}{P_2} > 1.89 \text{ use: } Q = \frac{KP_1}{2}$$

Where:

P₁ = Absolute Inlet Pressure (PSIA)

P₂ = Absolute Outlet Pressure (PSIA)

Q = Flow Rate (SCFH)

K = Orifice Coefficient (SCFH/PSI)

B34S SERIES COMMERCIAL REGULATOR, MODELS N & R

7" (17.5 mbar) Capacity Table (1" w.c. Droop*) 2" Outlet

Capacities in SCFH of 0.6 S.G. gas; base conditions of 14.7 PSIA and 60° F.

Typical Capacity Info.

Type and model	B34SR
Inlet size:	2" NPT
Outlet size:	2" NPT
Spring	Light Green

Inlet Pressure		Orifice									
PSIG	Bar	1/4"		1/4" x 3/8"		3/8"		3/8" x 1/2"		1/2"	
1	0.069	450	(12.7)	460	(13.0)	720	(20.3)	720	(20.3)	920	(26)
2	0.138	690	(19.5)	700	(19.8)	1030	(29.1)	1080	(30.5)	1450	(41.0)
3	0.207	850	(24.0)	860	(24.3)	1360	(38.5)	1420	(40.2)	1990	(56.3)
5	0.345	1100	(31.1)	1120	(31.7)	1860	(52.6)	1960	(55.5)	2850	(80.7)
10	0.69	1305	(36.9)	1365	(38.6)	2725	(77.1)	2865	(81.1)	5100	(144.4)
20	1.38	1900	(53.8)	2000	(56.6)	4110	(116.3)	4325	(122.4)	7125	(210.7)
30	2.07	2670	(75.6)	2810	(79.5)	5560	(157.4)	5640	(159.7)	7500	(212.3)
40	2.76	3250	(92.0)	3420	(96.8)	6675	(189.0)	7025	(198.9)	7500	(212.3)
50	3.45	3880	(109.8)	4080	(115.5)	7300	(206.7)	7500	(212.3)	7500	(212.3)
60	4.14	4620	(130.8)	4860	(137.6)	7500	(212.3)	7500	(212.3)	7500	(212.3)
70	4.83	5030	(142.4)	5235	(148.2)	7500	(212.3)				
80	5.52	5850	(165.6)	6120	(173.2)	7500	(212.3)				
90	6.21	6550	(185.4)	6825	(193.2)	7500	(212.3)				
100	6.90	6900	(195.3)	7250	(205.2)	7500	(212.3)				
125	8.63	7275	(206.0)	7500	(212.3)	7500	(212.3)				

Inlet Pressure ^A inches w.c.(mbar)	0.5 (1.3)	0.5 (1.3)	0.5 (1.3)	0.6 (1.4)	0.6 (1.4)
Lock Up ^B inches w.c. (mbar)	0.9 (1.7)	0.9 (1.7)	0.9 (1.7)	0.9 (1.4)	1.0 (1.8)

Notes:

*Individual regulator performance may vary from data shown.

A. Change in outlet pressure for 10 PSIG inlet pressure change.

B. Outlet pressure increase required for lock up.



Do not operate orifice in shaded inlet pressure area.

7" w.c. (17.5 mbar) Capacity Table (1" Droop) 2" Outlet continued

Capacities in SCFH of 0.6 S.G. gas; base conditions of 14.7 PSIA and 60° F.

Inlet Pressure		Orifice													
PSIG	Bar	1/2" x 5/8		5/8"		5/8" x 3/4"		3/4"		3/4" x 7/8"		7/8"		7/8" x 1"	
1	0.069	940	(26.2)	1130	(31.9)	1180	(33.4)	1245	(35.2)	1360	(38.5)	1425	(40.3)	1540	(43.6)
2	0.138	1520	(43.0)	1750	(49.5)	1830	(51.8)	2090	(59.1)	2200	(62.2)	2225	(63.0)	2300	(65.1)
3	0.207	2100	(59.4)	2395	(67.8)	2520	(71.3)	2850	(80.7)	3000	(84.9)	3250	(92.0)	3420	(96.8)
5	0.345	3000	(84.9)	3670	(103.9)	3820	(108.1)	4325	(122.4)	4550	(128.8)	4900	(138.7)	5150	(145.8)
10	0.69	5250	(148.6)	6270	(177.5)	6600	(186.8)	7125	(201.7)	7500	(212.3)	7500	(212.3)	7500	(212.3)
20	1.38	7500	(212.3)	7500	(212.3)										
30	2.07														
40	2.76														
50	3.45														
60	4.14														
70	4.83														
80	5.52														
90	6.21														
100	6.90														
125	8.63														

Inlet Pressure ^A inches w.c.(mbar)	0.6 (1.4)	0.8 (1.6)	0.8 (1.6)	0.8 (1.6)	0.8 (1.6)	1.0 (1.8)	1.0 (1.8)
Lock Up ^B inches w.c. (mbar)	1 (1.8)	1.0 (1.8)	1.0 (1.8)	1.1 (1.9)	1.1 (1.9)	1.2 (2.0)	1.2 (2.0)

Notes:

*Individual regulator performance may vary from data shown.

A. Change in outlet pressure for 10 PSIG inlet pressure change.

B. Outlet pressure increase required for lock up.

Do not operate orifice in shaded inlet pressure area.

B34S PERFORMANCE CURVES

7" w.c. Set Point

Type and model B34S R

Inlet size 2" NPT

Outlet size 2" NPT

Orifice size 1/4" x 3/8"

All test results are reported at a base of 14.7 PSIA at 60° F and with 0.6 S.G. gas.

B34 SR & SN Regulator Performance

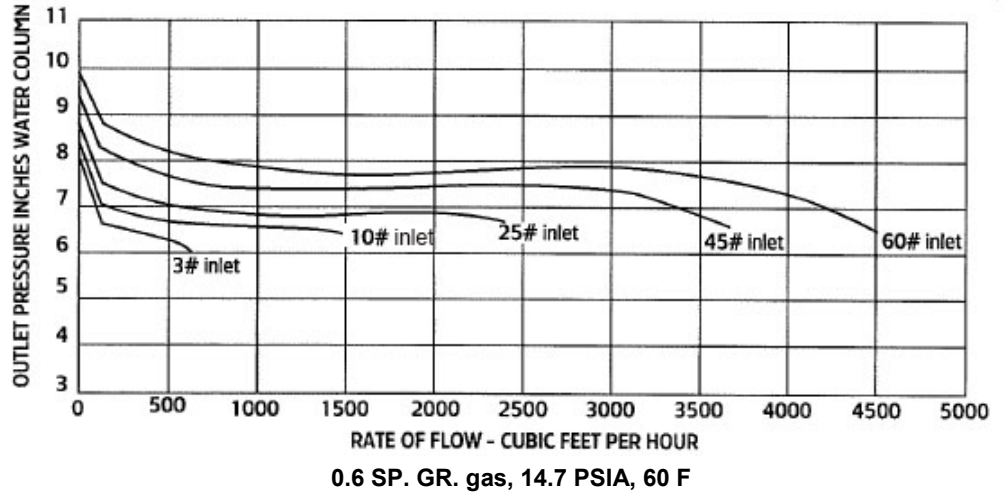

RELIEF CURVES

7" w.c. Set Point

Inlet size 2" NPT

Outlet size 2" NPT

Vent size 1" NPT

All test results are reported at a base of 14.7 PSIA at 60° F and with 0.6 S.G. gas.

Set point 7.0" w.c. with 40 PSIG inlet at 100 SCFH.

B34 SR & SN Regulator Relief Curve Blocked per Orifice

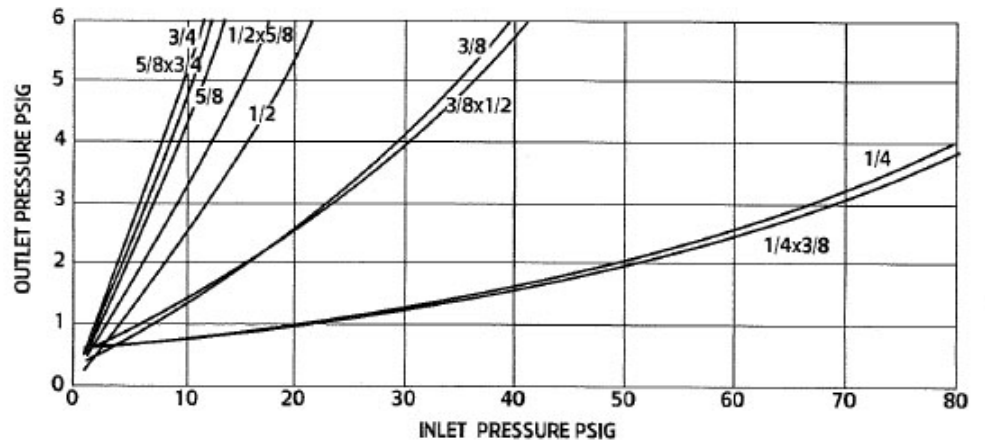

B34S SERIES COMMERCIAL REGULATOR, MODELS N & R

14" w.c. (35 mbar) Capacity Table (2" w.c. Droop*) 2" Outlet

Capacities in SCFH of 0.6 S.G. gas; base conditions of 14.7 PSIA and 60° F.

Typical Capacity Info.

Type and model	B34SR
Inlet size	2" NPT
Outlet size	2" NPT
Spring	Silver

Inlet Pressure		Orifice Size							
PSIG	Bar	1/4"		1/4" x 3/8"		3/8"		3/8" x 1/2"	
1	0.069	310	(8.7)	330	(9.3)	620	(17.5)	625	(17.6)
2	0.138	520	(14.7)	530	(15.0)	1000	(28.3)	1010	(28.6)
3	0.207	650	(18.4)	665	(18.8)	1225	(34.6)	1240	(35.1)
5	0.345	790	(22.3)	810	(22.9)	1710	(48.4)	1740	(49.2)
10	0.69	1300	(36.4)	1320	(37.3)	2950	(83.5)	3000	(84.9)
20	1.38	1920	(54.3)	1950	(55.2)	4260	(120.6)	4300	(121.7)
30	2.07	2625	(74.3)	2800	(79.2)	5500	(155.7)	5610	(158.8)
40	2.76	2960	(83.8)	3045	(86.2)	6400	(181.2)	6850	(193.9)
50	3.45	3690	(104.4)	3750	(106.1)	7480	(211.8)	7500	(212.3)
60	4.14	4500	(126.0)	4700	(131.6)	7500	(212.3)	7500	(212.3)
70	4.83	5120	(144.9)	5275	(149.3)	7500	(212.3)		
80	5.52	5400	(151.2)	5660	(160.2)	7500	(212.3)		
90	6.21	6215	(173.4)	6250	(176.9)	7500	(212.3)		
100	6.90	6400	(181.2)	6600	(186.8)	7500	(212.3)		
125	8.63	7390	(209.2)	7500	(212.3)	7500	(212.3)		

Inlet Pressure ^A (inches w.c.)	0.6 (1.4)	0.6 (1.4)	0.7 (1.5)	0.7 (1.5)
Lock Up ^B (inches w.c.)	0.5 (1.3)	0.5 (1.3)	0.5 (1.03)	0.5 (1.3)

Notes:

*Individual regulator performance may vary from data shown.

A. Change in outlet pressure for 10 PSIG inlet pressure change.

B. Outlet pressure increase required for lock up.



Do not operate orifice in shaded inlet pressure area.

14" w.c. (35 mbar) Capacity Table (2" Droop) 2" Outlet continued

Capacities in SCFH of 0.6 S.G. gas; base conditions of 14.7 PSIA and 60° F.

Inlet Pressure		Orifice Size																									
PSIG	Bar	1/2"		1/2" x 5/8"		5/8"		5/8" x 3/4"		3/4"		3/4" x 7/8"		7/8"		7/8" x 1"											
1	0.069	740	(20.9)	760	(21.5)	800	(22.6)	830	(23.5)	920	(26.0)	980	(27.7)	980	(27.7)	1100	(31.1)										
2	0.138	1090	(30.8)	1150	(32.5)	1460	(41.3)	1500	(42.4)	1550	(43.8)	1620	(45.8)	1800	(50.9)	1880	(53.2)										
3	0.207	1300	(36.8)	1550	(43.8)	1770	(50.1)	1800	(50.9)	2060	(58.3)	2240	(63.4)	2510	(71.0)	2600	(73.6)										
5	0.345	1990	(56.3)	2200	(62.2)	2780	(78.7)	2940	(83.2)	3500	(99.1)	3700	(104.7)	4080	(115.5)	4300	(121.7)										
10	0.69	3720	(105.3)	4550	(128.8)	5700	(161.4)	6000	(169.9)	7130	(201.8)	7400	(209.5)	7500	(212.3)	7500	(212.3)										
20	1.38	4700	(133.0)	7500	(212.3)	7500	(212.3)																				
30	2.07	5900	(167.0)																								
40	2.76	6800	(192.5)																								
50	3.45	7500	(212.3)																								
60	4.14	7500	(212.3)																								
70	4.83																										
80	5.52																										
90	6.21																										
100	6.90																										
125	8.63																										

Inlet Pressure ^A (inches w.c.)	0.7 (1.5)	0.7 (1.5)	0.9 (1.7)	0.9 (1.7)	0.9 (1.7)	0.9 (1.7)	1.4 (2.9)	1.4 (2.9)
Lock Up ^B (inches w.c.)	0.8 (1.6)	0.8 (1.6)	0.9 (1.7)	0.9 (1.7)	1.0 (1.8)	1.0 (1.8)	1.3 (2.8)	1.3 (2.8)

Notes:

*Individual regulator performance may vary from data shown.

A. Change in outlet pressure for 10 PSIG inlet pressure change.

B. Outlet pressure increase required for lock up.

Do not operate orifice in shaded inlet pressure area.

B34S PERFORMANCE CURVES

14" w.c. Set Point

Type and model	B34S R
Inlet size	2" NPT
Outlet size	2" NPT
Orifice size	1/4" x 3/8"

All test results are reported at a base of 14.7 PSIA at 60° F and with 0.6 S.G. gas.

B34 SR & SN Regulator Performance

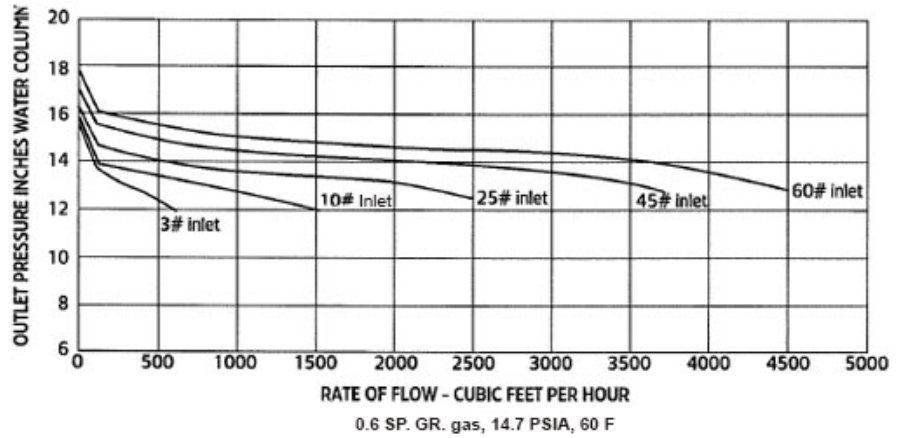

RELIEF CURVES

14" w.c. Set Point

Inlet size	2" NPT
Outlet size	2" NPT
Vent size	1" NPT

All test results are reported at a base of 14.7 PSIA at 60° F and with 0.6 S.G. gas.

Set point 14" w.c. with 40 PSIG inlet at 100 SCFH.

B34 SR & SN Regulator Relief Curve Blocked per Orifice

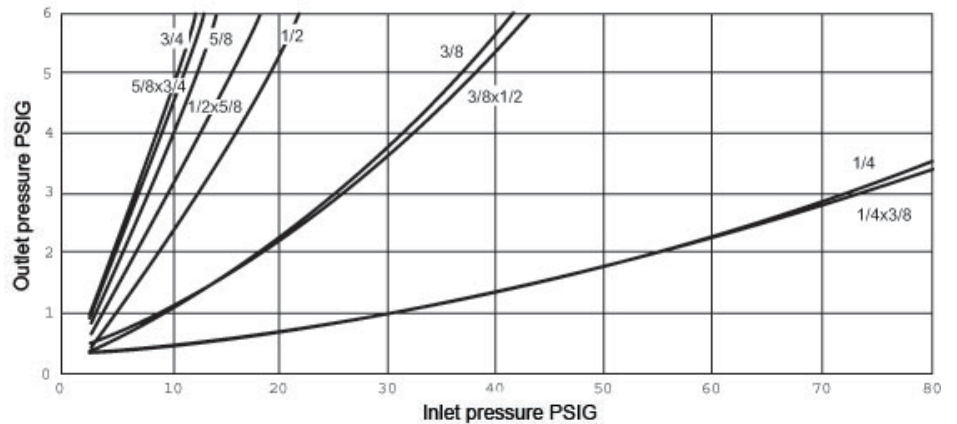

B34S SERIES COMMERCIAL REGULATOR, MODELS NHP AND RHP

1 PSIG (69 mbar) Capacity Table (1% Absolute Droop*) 2" Outlet

Capacities in SCFH of 0.6 S.G. gas; base conditions of 14.7 PSIA and 60° F.

Typical Capacity Info.

Type and model	B34SRHP
Inlet size	2" NPT
Outlet size	2" NPT
Spring	Red/gray

Inlet Pressure		Orifice Size											
PSIG	Bar	1/4"		1/4" x 3/8"		3/8"		3/8" x 1/2"		1/2"		1/2" x 5/8"	
2	0.138	420	(11.8)	425	(12.0)	560	(15.8)	580	(16.4)	700	(19.8)	720	(20.3)
3	0.207	580	(16.4)	590	(16.7)	760	(21.5)	780	(22.0)	910	(25.7)	940	(26.6)
5	0.345	780	(22.0)	800	(22.6)	990	(28.0)	1080	(30.5)	1250	(35.3)	1300	(36.8)
10	0.69	1090	(30.8)	1130	(31.9)	1670	(47.2)	1720	(48.7)	1950	(55.2)	2100	(59.4)
20	1.38	1690	(47.8)	1770	(50.1)	2920	(82.6)	3100	(87.7)	4050	(114.6)	4200	(118.9)
30	2.07	2250	(63.7)	2330	(65.9)	3900	(110.4)	4000	(113.2)	4400	(124.5)		
40	2.76	2900	(82.1)	3050	(86.3)	4680	(132.5)	4800	(135.9)	5100	(144.4)		
50	3.45	3580	(101.3)	3700	(104.7)	7350	(208.1)	7500	(212.3)	7500	(212.3)		
60	4.14	4250	(120.3)	4400	(124.5)	7500	(212.3)	7500	(212.3)	7500	(212.3)		
70	4.83	5275	(149.3)	5360	(151.7)	7500	(212.3)						
80	5.52	5625	(159.2)	5700	(161.4)	7500	(212.3)						
90	6.21	5795	(164.0)	5880	(166.5)	7500	(212.3)						
100	6.90	5900	(167.0)	6050	(171.3)	7500	(212.3)						
125	8.63	6250	(176.9)	6500	(184.0)	7500	(212.3)						

Inlet Pressure ^A (PSIG)	0.02 (1.38)	0.02 (1.38)	0.03 (2.06)	0.03 (2.06)	0.04 (2.75)	0.04 (2.75)
Lock Up ^B (PSIG)	0.04 (2.75)	0.04 (2.75)	0.05 (3.44)	0.05 (3.44)	0.05 (3.44)	0.05 (3.44)

Notes:

*Individual regulator performance may vary from data shown.

A. Change in outlet pressure for 10 PSIG inlet pressure change.

B. Outlet pressure increase required for lock up.



Do not operate orifice in shaded inlet pressure area.

1PSIG (60 mbar) Capacity Table (1% Absolute Droop) 2" Outlet continued

Capacities in SCFH of 0.6 S.G. gas; base conditions of 14.7 PSIA and 60° F.

Inlet Pressure		Orifice Size											
PSIG	Bar	5/8"		5/8" x 3/4"		3/4"		3/4" x 7/8"		7/8"		7/8" x 1"	
2	0.138	800	(22.6)	890	(25.2)	925	(26.1)	1000	(28.3)	1070	(30.2)	1120	(31.7)
3	0.207	1125	(31.8)	1200	(33.9)	1270	(33.9)	1300	(36.8)	1490	(42.1)	1540	(43.6)
5	0.345	1410	(39.9)	1560	(44.1)	1780	(50.4)	1840	(52.1)	2100	(59.4)	2220	(62.8)
10	0.69	2590	(73.3)	2750	(77.8)	3520	(99.6)	3640	(103.0)	3800	(107.6)	3900	(110.4)
20	1.38	3000	(84.9)										
30	2.07												
40	2.76												
50	3.45												
60	4.14												
70	4.83												
80	5.52												
90	6.21												
100	6.90												
125	8.63												

Inlet Pressure ^A (PSIG)	0.04 (2.75)	0.04 (2.75)	0.05 (3.44)	0.05 (3.44)	0.07 (4.82)	0.07 (4.82)
Lock Up ^B (PSIG)	0.05 (3.44)	0.05 (3.44)	0.05 (3.44)	0.05 (3.44)	0.05 (3.44)	0.05 (3.44)

Notes:

*Individual regulator performance may vary from data shown.

A. Change in outlet pressure for 10 PSIG inlet pressure change.

B. Outlet pressure increase required for lock up.



Do not operate orifice in shaded inlet pressure area.

B34S SERIES COMMERCIAL REGULATOR, MODELS NHP AND RHP

1 PSIG Capacity Table (2% Absolute Droop*) 2" Outlet

Capacities in SCFH of 0.6 S.G. gas; base conditions of 14.7 PSIA and 60° F.

Typical Capacity Info.	Inlet Pressure		Orifice Size											
	PSIG	Bar	1/4"		1-1/4 x 3/8"		3/8"		3/8" x 1/2"		1/2"		1/2" x 5/8"	
Type and model B34SRHP	2	0.138	500	(14.1)	560	(15.8)	900	(25.4)	930	(26.3)	1090	(30.8)	1180	(33.4)
Inlet size 2" NPT	3	0.207	700	(19.6)	750	(21.2)	1190	(33.6)	1250	(35.3)	1520	(43.0)	1600	(45.3)
Outlet size 2" NPT	5	0.345	900	(25.4)	970	(27.4)	1720	(48.7)	1800	(50.9)	2180	(61.7)	2240	(63.4)
Spring Red/gray	10	0.69	1300	(36.8)	1390	(39.3)	2780	(78.7)	2840	(80.4)	3550	(100.5)	3620	(102.5)
	20	1.38	2120	(60.0)	2200	(62.2)	4400	(124.5)	4500	(127.4)	7200	(203.8)	7350	(208.1)
	30	2.07	2740	(77.5)	2825	(79.9)	5625	(159.2)	5775	(163.5)	7500	(212.3)		
	40	2.76	2980	(84.3)	3100	(87.7)	6190	(175.2)	6350	(179.8)	7500	(212.3)		
	50	3.45	3610	(102.2)	3700	(104.7)	7425	(210.2)	7500	(212.3)	7500	(212.3)		
	60	4.14	4600	(130.2)	4700	(133.0)	7500	(212.3)	7500	(212.3)	7500	(212.3)		
	70	4.83	4960	(140.5)										
	80	5.52	5875	(166.3)										
	90	6.21	6100	(172.7)										
	100	6.90	6425	(181.9)										
	125	8.63	7500	(212.3)										

Inlet Pressure ^A (PSIG)	0.02 (1.38)	0.02 (1.38)	0.03 (2.06)	0.03 (1.38)	0.04 (2.75)	0.04 (2.75)
Lock Up ^B (PSIG)	0.04 (2.75)	0.04 (2.75)	0.05 (3.44)	0.05 (3.44)	0.05 (3.44)	0.05 (3.44)

Notes:

*Individual regulator performance may vary from data shown.

A. Change on outlet pressure for 10 PSIG inlet pressure change.

B. Outlet pressure increase required for lock up.



Do not operate orifice in shaded inlet pressure area.

1 PSIG (69 mbar) Capacity Table (2% Absolute Droop) 2" Outlet continued

Capacities in SCFH of 0.6 S.G. gas; base conditions of 14.7 PSIA and 60° F.

Inlet Pressure		Orifice Size											
PSIG	Bar	5/8"		5/8" x 3/4"		3/4"		3/4" x 7/8"		7/8"		7/8" x 1"	
2	0.138	1370	(38.8)	1460	(41.3)	1680	(47.5)	1720	(48.7)	1800	(50.9)	1920	(54.3)
3	0.207	1810	(51.2)	1980	(56.0)	2190	(62.0)	2300	(65.1)	2480	(70.2)	2620	(74.1)
5	0.345	2650	(75.0)	2820	(79.8)	3180	(90.0)	3300	(93.4)	3710	(105.0)	3800	107.6)
10	0.69	4600	(130.2)	4750	(134.5)	5580	(158.0)	5750	(162.8)	6375	(180.5)	6500	(184.0)
20	1.38	4800	(135.9)										
30	2.07												
40	2.76												
50	3.45												
60	4.14												
70	4.83												
80	5.52												
90	6.21												
100	6.90												
125	8.63												

Inlet Pressure ^A (PSIG)	0.04 (2.75)	0.04 (2.75)	0.05 (3.44)	0.05 (3.44)	0.07 (4.82)	0.07 (4.82)
Lock Up ^B (PSIG)	0.05 (3.44)	0.05 (3.44)	0.05 (3.44)	0.05 (3.44)	0.05 (3.44)	0.05 (3.44)

Notes:

*Individual regulator performance may vary from data shown.

A. Change on outlet pressure for 10 PSIG inlet pressure change.

B. Outlet pressure increase required for lock up.

Do not operate orifice in shaded inlet pressure area.

B34SRHP PERFORMANCE CURVES

1 PSIG Set Point

Type and model	B34SRHP
Inlet size	2" NPT
Orifice size	1/4" x 3/8"

All test results are reported at a base of 14.7 PSIA at 60° F and with 0.6 S.G. gas.

B34 SR & SN Regulator Performance

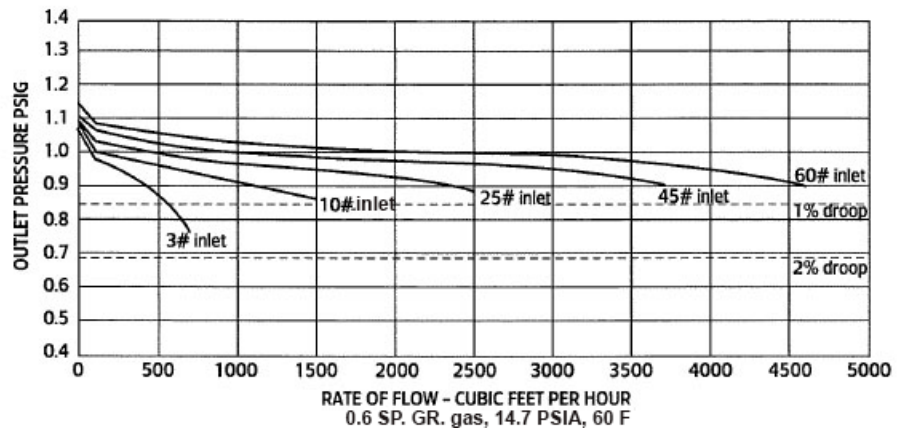

B34SRHP RELIEF CURVES

1 PSIG Set Point

Inlet size	2" NPT
Outlet size	2" NPT
Vent size	1" NPT

All test results are reported at a base of 14.7 PSIA at 60° F and with 0.6 S.G. gas.

Set point 1.0 PSIG with 40 PSIG inlet at 200 SCFH.

B34 SR & SN Regulator Relief Curve Blocked per Orifice

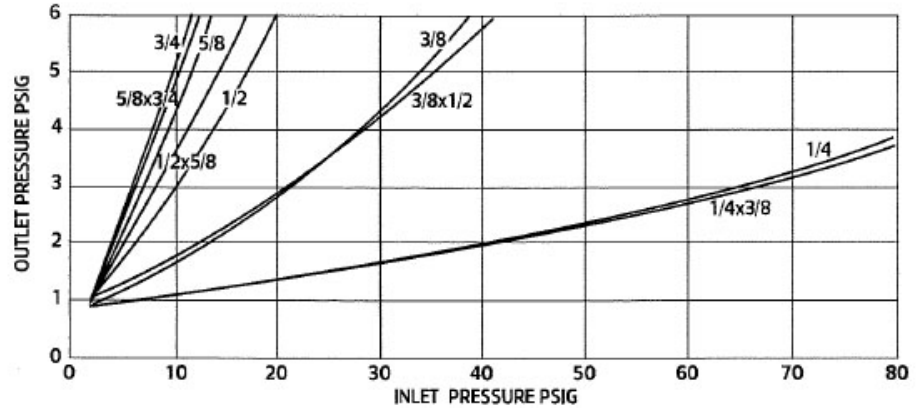

B34SRHP SERIES COMMERCIAL REGULATOR

2 PSIG (69 mbar) Capacity Table (1% Absolute Droop*) 2" Outlet

Capacities in SCFH of 0.6 S.G. gas; base conditions of 14.7 PSIA and 60° F.

Typical Capacity Info.

Type and model	B34SRHP
Inlet size	2" NPT
Outlet size	2" NPT
Spring	White

Inlet Pressure	Orifice Size												
	PSIG	Bar	1/4"		1-1/4 x 3/8"		3/8"		3/8" x 1/2"		1/2"		1/2" x 5/8"
3	0.207	300	(8.4)	305	(8.6)	420	(11.8)	490	(13.8)	500	(14.1)	510	(14.4)
5	0.345	410	(11.6)	445	(12.6)	650	(18.4)	700	(19.8)	720	(20.3)	760	(21.5)
10	0.69	540	(15.2)	560	(15.8)	900	(25.4)	990	(28.0)	1175	(33.2)	1220	(34.5)
20	1.38	800	(22.6)	850	(24.0)	1450	(41.0)	1550	(43.8)	1625	(46.0)	1710	(48.4)
30	2.07	980	(27.7)	1100	(31.1)	1875	(53.0)	1950	(55.2)	2100	(59.4)		
40	2.76	1150	(32.5)	1300	(36.8)	2000	(56.6)	2200	(62.2)	2500	(70.7)		
50	3.45	1425	(40.3)	1500	(42.4)	3100	(87.7)	3550	(100.5)	3640	(103.0)		
60	4.14	1610	(45.5)	1750	(49.5)	3500	(99.1)	3750	(106.1)	3900	(110.4)		
70	4.83	1900	(53.8)	2000	(56.6)	3700	(104.7)						
80	5.52	2300	(65.1)	2500	(70.7)	3975	(112.5)						
90	6.21	2550	(72.2)	2600	(73.6)	4200	(118.9)						
100	6.90	2680	(75.8)	2730	(77.3)	4500	(127.4)						
125	8.63	4000	(113.2)	4200	(118.9)	4700	(133.0)						

Inlet Pressure ^A (PSIG)	0.02 (1.38)	0.02 (1.38)	0.02 (1.38)	0.02 (1.38)	0.03 (2.07)	0.03 (2.07)
Lock Up ^B (PSIG)	0.03 (2.07)	0.03 (2.07)	0.03 (2.07)	0.03 (2.07)	0.03 (2.07)	0.03 (2.07)

Notes:

*Individual regulator performance may vary from data shown.

A. Change in outlet pressure for 10 PSIG inlet pressure change.

B. Outlet pressure increase required for lock up.

Do not operate orifice in shaded inlet pressure area.

2 PSIG (69 mbar) Capacity Table (1% Absolute Droop*) 2" Outlet continued

Capacities in SCFH of 0.6 S.G. gas; base conditions of 14.7 PSIA and 60° F.

Inlet Pressure		Orifice Size											
PSIG	Bar	5/8"		5/8 x 3/4"		3/4"		3/4" x 7/8"		7/8"		7/8" x 1"	
3	0.207	550	(15.1)	600	(16.9)	625	(17.6)	650	(18.4)	750	(21.2)	770	(21.8)
5	0.345	800	(22.6)	860	(24.3)	925	(26.1)	1030	(29.1)	1100	(31.1)	1170	(33.1)
10	0.69	1300	(36.8)	1420	(40.2)	1650	(46.7)	1740	(49.2)	1900	(53.8)	2040	(57.7)
20	1.38	1500	(42.4)										
30	2.07												
40	2.76												
50	3.45												
60	4.14												
70	4.83												
80	5.52												
90	6.21												
100	6.90												
125	8.63												

Inlet Pressure ^A (PSIG)	0.03 (2.07)	0.03 (2.07)	0.03 (2.07)	0.03 (2.07)	0.03 (2.07)	0.03 (2.07)
Lock Up ^B (PSIG)	0.04 (2.76)	0.04 (2.76)	0.04 (2.76)	0.06 (4.14)	0.07 (4.83)	0.07 (4.83)

Notes:

*Individual regulator performance may vary from data shown.

A. Change in outlet pressure for 10 PSIG inlet pressure change.

B. Outlet pressure increase required for lock up.

Do not operate orifice in shaded inlet pressure area.

B34S SERIES COMMERCIAL REGULATOR, MODELS SN AND SR

2 PSIG (69 mbar) Capacity Table (2% Absolute Droop*) 2" Outlet

Capacities in SCFH of 0.6 S.G. gas; base conditions of 14.7 PSIA and 60° F.

Typical Capacity Info.

Type and model	B34SRHP
Inlet size	2" NPT
Outlet size	2" NPT
Position	11
Spring	Silver

Inlet Pressure		Orifice Size											
PSIG	Bar	1/4"		1-1/4 x 3/8"		3/8"		3/8" x 1/2"		1/2"		1/2" x 5/8"	
3	0.207	450	(12.7)	470	(13.3)	600	(16.9)	800	(22.6)	875	(24.7)	920	(26.0)
5	0.345	700	(19.8)	775	(21.9)	1100	(31.1)	1200	(33.9)	1350	(38.2)	1440	(40.7)
10	0.69	900	(25.4)	1020	(28.8)	1780	(50.4)	1920	(54.3)	2200	(62.2)	2320	(65.6)
20	1.38	1500	(42.4)	1650	(46.2)	3000	(84.9)	3200	(90.6)	3800	(107.6)	3950	(111.8)
30	2.07	2000	(56.6)	2200	(62.2)	4000	(113.2)	4350	(123.1)	4500	(127.4)		
40	2.76	2400	(67.9)	2600	(73.6)	4800	(135.9)	5200	(147.2)	5600	(158.5)		
50	3.45	3100	(87.7)	3300	(114.8)	6000	(169.9)	7500	(212.3)	7500	(212.3)		
60	4.14	3800	(107.6)	4000	(113.2)	7500	(212.3)	7500	(212.3)	7500	(212.3)		
70	4.83	3950	(111.8)	4100	(116.0)	7500	(212.3)						
80	5.52	4275	(121.0)	4500	(127.4)	7500	(212.3)						
90	6.21	4600	(130.2)	5200	(147.2)	7500	(212.3)						
100	6.90	5000	(141.5)	5440	(154.0)	7500	(212.3)						
125	8.63	6000	(169.9)	6200	(175.5)	7500	(212.3)						

Inlet Pressure ^A (PSIG)	0.02 (1.38)	0.02 (1.38)	0.02 (1.38)	0.02 (1.38)	0.03 (2.07)	0.03 (2.07)
Lock Up ^B (PSIG)	0.03 (2.07)	0.03 (2.07)	0.03 (2.07)	0.03 (2.07)	0.03 (2.07)	0.03 (2.07)

Notes:

*Individual regulator performance may vary from data shown.

A. Change in outlet pressure for 10 PSIG inlet pressure change.

B. Outlet pressure increase required for lock up.

Do not operate orifice in shaded inlet pressure area.

2 PSIG (69 mbar) Capacity Table (2% Absolute Droop*) 2" Outlet continued

Capacities in SCFH of 0.6 S.G. gas; base conditions of 14.7 PSIA and 60° F.

Inlet Pressure		Orifice Size											
PSIG	Bar	5/8"		5/8 x 3/4"		3/4"		3/4" x 7/8"		7/8"		7/8" x 1"	
3	0.207	1000	(28.3)	1120	(31.7)	1200	(33.9)	1230	(34.8)	1300	(36.8)	1480	(41.9)
5	0.345	1500	(42.4)	1690	(47.8)	1900	(53.8)	2100	(59.4)	2200	(62.2)	2300	(65.1)
10	0.69	2500	(70.7)	2760	(78.1)	3300	(93.4)	3750	(106.1)	4000	(113.2)	4200	(118.9)
20	1.38	3500	(99.1)										
30	2.07												
40	2.76												
50	3.45												
60	4.14												
70	4.83												
80	5.52												
90	6.21												
100	6.90												
125	8.63												

Inlet Pressure ^A (PSIG)	0.03 (2.07)	0.03 (2.07)	0.03 (2.07)	0.03 (2.07)	0.03 (2.07)	0.03 (2.07)
Lock Up ^B (PSIG)	0.04 (2.76)	0.04 (2.76)	0.04 (2.76)	0.06 (4.14)	0.07 (4.83)	0.07 (4.83)

Notes:

*Individual regulator performance may vary from data shown.

A. Change in outlet pressure for 10 PSIG inlet pressure change.

B. Outlet pressure increase required for lock up.

Do not operate orifice in shaded inlet pressure area.

B34SRHP PERFORMANCE CURVES

2 PSIG Set Point

Type and model	B34SRHP, NHP
Inlet size	2" NPT
Outlet size	2" NPT
Orifice size	1/4" x 3/8"
Spring	Silver

All test results are reported at a base of 14.7 PSIA at 60°F and with 0.6 S.G. gas.

B34SRHP Regulator Performance, 2 PSIG Set Point

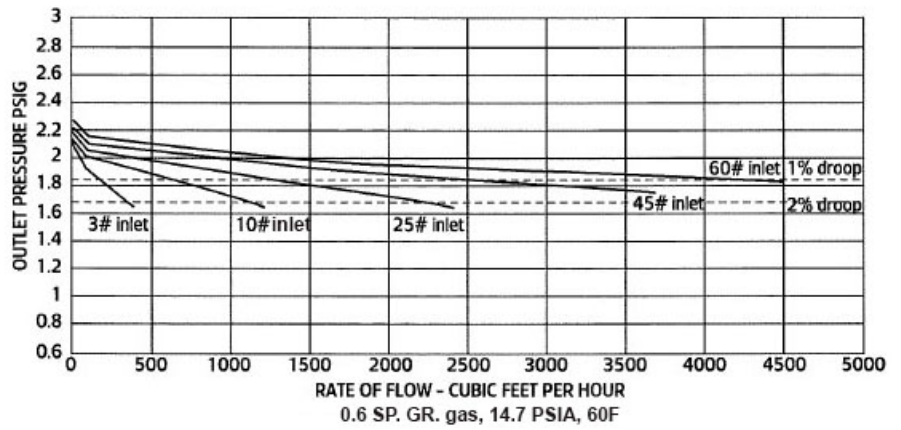

B34SRHP RELIEF CURVES

2 PSIG Set Point

Inlet size	2" NPT
Outlet size	2" NPT
Vent size	1" NPT

All test results are reported at a base of 14.7 PSIG at 60° F and with 0.6 S.G. gas.

Set point 2 PSIG with 40 PSIG inlet pressure at 100 SCFH.

B34SRHP Relief Curves, Blocked per Orifice, 2 PSIG Set Point

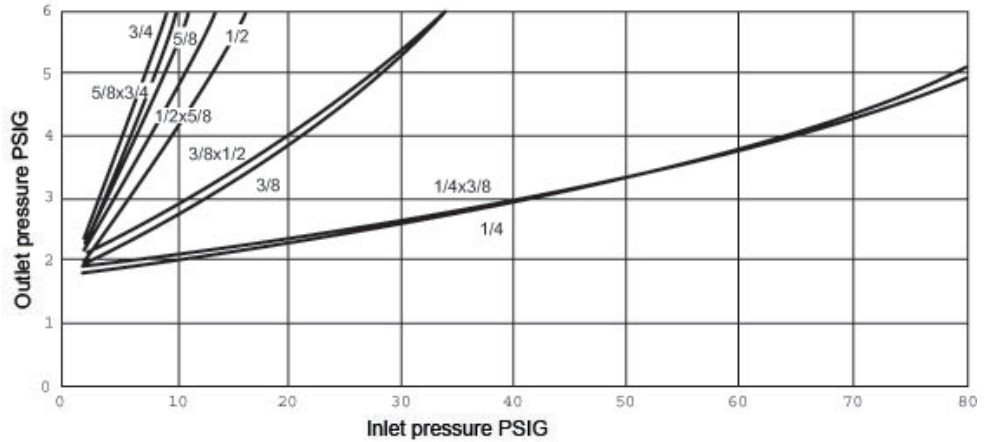

ASSEMBLY POSITIONS

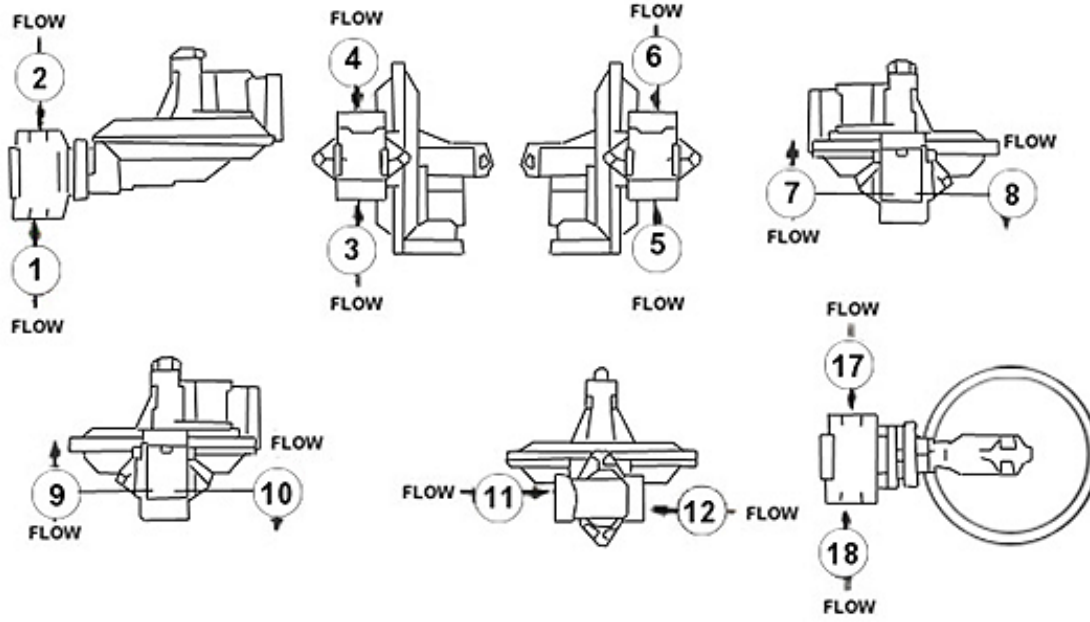

PARTS LIST

B34SR and B34SRHP

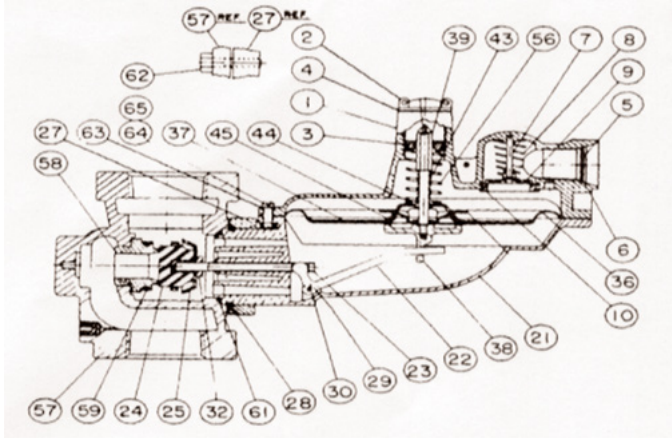

B34SN and B34SNHP

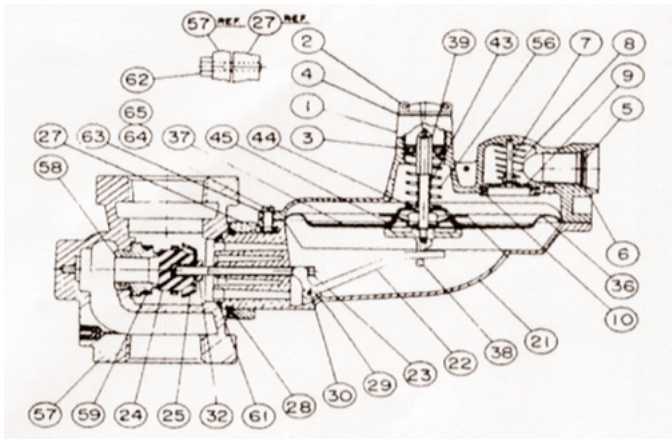

Item Number	Part Number	Qty. Required per Regulator Model				Description
		SRHP	SNHP	SR	SN	
1						Upper diaphragm case, please specify vent pipe size
	753103-0500			1	1	1/4" Standard top casting
	753107-0500	1	1			1/4" HP top casting
	753127-0500			1	1	3/8" Top casting
	753154-0500			1	1	3/4" Standard top casting
	753157-0500	1	1			3/4" HP top casting
	753234-0500			1	1	1" Standard top casting
	753237-0500	1	1			1" HP top casting
2						Seal cap, please specify color
	760058-001			1	1	Gray standard IWC seal cap with O-ring gasket
	760060-001			1	1	Red standard IWC seal cap with O-ring gasket
	760066-001			1	1	Green standard IWC seal cap with O-ring gasket
	760059-001	1	1			Red HP PSIG seal cap with O-ring gasket
	760062-001	1	1			Gray HP PSIG seal cap with O-ring gasket
3						Adjustment screw
	760215			1	1	Delrin (for inches w.c. outlet pressure)
	760217					Aluminum (for PISG outlet pressure)
4	765503	1	1	1	1	Seal cap gasket

Item Number	Part Number	Qty. Required per Regulator Model				Description
		SRHP	SNHP	SR	SN	
5		1	1	1	1	Vent screen, please specify top size:
	762935					For all vents except 1"
	762933					For 1" vent only
6		1	1	1	1	Vent screen retaining ring, please specify top size:
	75572701					For all vents except 1"
	75579101					For 1" vent only
7		1	1	1	1	Vent valve disc pin, please specify:
	754806					For all vents except 1"
	75483401					For 1" vent only
8	762651	1	1	1	1	Vent valve spring
9	765181	1	1	1	1	Vent valve disc
10	765685	1	1	1	1	Vent valve seat
21	752124-0500	1	1	1	1	Lower diaphragm case, 4:1 ratio
22	761231	1	1	1	1	Valve linkage lever, 4:1 ratio
23	754021	1	1	1	1	Valve stem, aluminum Note: requires #32 valve stem adaptor
24	765201	1	1	1	1	Valve seat Buna "N" 75-85 Durometer
25	761721	1	1	1	1	Deflector
27						**no longer required**
28						**no longer required**
29	755141-001	2	2	2	2	Valve linkage pin screw
30	754831	1	1	1	1	Valve linkage pin
32	754085	1	1	1	1	Valve stem adapter
36	766130	1	1	1	1	Diaphragm, .028 nylon fabric with Buna "N"
37	76102601	1	1	1	1	Upper diaphragm plate
38	756043	1	1	1	1	Lower diaphragm plate
39						Stop stem
	754301	1		1		Relief version
	754303		1		1	Non-relief version
43		1		1		Relief spring
	762101					7" w.c. above set point (standard)
	762103					10" w.c. above set point
44	75490601	1	1			Stop stem guide bushing
45						**no longer required**
54	755801			1	1	Diaphragm washer plate
56				1	1	Adjustment spring, please specify
	762018	1	1			Red/blue
	762111	1	1			Brown 4.5-5.5" w.c.
	762117	1	1			D. Green 5.0-7.0" w.c.
	762119			1	1	L. Green 5.5-8.0" w.c.
	762123			1	1	Black 7.0-11.0 w.c.
	762127			1	1	Blue 8.0-12.0" w.c.
	762129			1	1	Silver 11.0-16.0" w.c.
	762131	1	1			Yellow 1.1-1.5 PSIG
	762135	1	1			Red 1.3-2.0 PSIG
	762137	1	1			White 1.75-2.5 PSIG
	762025	1	1			Red/gray .75-1.1 PSIG
	762139	1	1			Gray

Item Number	Part Number	Qty. Required per Regulator Model				Description
		SRHP	SNHP	SR	SN	
57		1	1	1	1	Valve body, please specify type & size
Straight:						
	750604 -0500					1-1/4" x 1-1/4" NPT
	750605-0500					1-1/4" x 1-1/4" BSPT
	750607					1-1/4" x 1-1/4" NPT with 1/8 NPT upstream pipe plug
	750627-0500					1-1/4" x 1-1/2" NPT (standard)
	750630					1-1/4" x 1-1/2" NPT with 1/8 NPT upstream pipe plug
	750654-0500					1-1/4" x 2" NPT (standard)
	750657					1-1/4" x 2" NPT with 1/8" NPT upstream pipe plug
	750676-0500					1-1/2" x 1-1/2" NPT (standard)
	750680					1-1/2" x 1-1/2" NPT with 1/8" NPT upstream pipe plug
	750704-0500					1-1/2" x 2" NPT (standard)
	750707					1-1/2" x 2" NPT with 1/8" NPT upstream pipe plug
	750726-0500					2" x 2" NPT (standard)
	750728-0500					2" x 2" BSPT
	750729-0500					2" x 2" BSP
	750730					2" x 2" NPT with 1/8" NPT upstream pipe plug
Flanged - 125 Class						
	750754-0500					2"x 2" flanged, 10" length (standard)
	750757					2" s 2" flanged, 10" length 1/8" upstream pipe plug
	750804-0500					3" x 3" flanged, (standard)
	750807					3" x 3" flanged, with 1/8 upstream tap
	750777-0500					2" x 2" flanged, 7.5" length
	750780					2" x 2" flanged, 7.5" length, upstream tap.
Orifice - please specify						
Straight, brass						
	758101					1/4" diameter
	758104					3/8" diameter
	758107					1/2" diameter
	758110					5/8" diameter
	758113					3/4" diameter
	758117					7/8" diameter
Tapered, brass						
	758150					7/32" x 1/4" diameter
	758151					1/4" x 3/8" diameter
	758154					5/16" x 3/8" diameter
	758157					3/8" x 1/2" diameter
	758160					1/2" x 5/8" diameter
	758163					5/8" x 3/4" diameter
	758166					3/4" x 7/8" diameter
	758169					7/8" x 1" diameter
59	761761	1	1	1	1	Loading ring
61	765651	1	1	1	1	Valve body gasket
62	755386-001	2	2	2	2	Retainer plate screw hex head-steel; 5/16-16 x 1-1/8" length
63	769151	1	1	1	1	Curved regulator plate-as silk screened and embossed
64	755304-001	8	8	8	8	Case screw, 1/4-20 x 3/4 Hex head
65	755513-001	8	8	8	8	Case screw nut 1/4-20 Hex head

Part Number	Quantity per regulator				Description
	SRHP	SNHP	SR	SN	
715019	1	1	1	1	Lower diaphragm case assembly
720010	1		1		Diaphragm assembly (standard 7 inches w.c. above set relief spring)
720011	1		1		Diaphragm assembly (10 inches w.c. above set relief spring)
720019		1		1	Diaphragm assembly (N version)

Special Parts

Part No.	Description
80002001	Seal wire - no lead
799051	Spring adjusting wrench
799081	Loading ring positioning tool
799017	Thin-walled 7/8" orifice socket
754852	Vent valve reducer #31 (for inlet pressure <60 PSIG)
754853	Vent valve reducer #44 (for inlet pressure > 60 PSIG)

Torque specifications	
Retainer plate screws	100 in-lbs
Orifice	600 in-lbs
Margin (diaphragm case screws)	27-30 in-lbs

VENT LINES FOR REGULATORS

When constructing vent lines to be attached to regulators installed indoors, follow a few basic rules:

- a. Never use pipe sizes smaller than the vent size; smaller pipe sizes restrict the gas flow. If a long gas run must be used, Itron advises increasing the pipe one nominal size every ten feet to keep the flow restriction as low as possible.
- b. Keep the vent line length as short as possible to minimize the restriction and reduce the vent's tendency to cause regulator pulsation.
- c. Support the vent pipe to eliminate strain on the regulator diaphragm case.
- d. Always point outdoor vent pipes in the downward position to reduce the possibility of rain, snow, sleet, and other moisture entering the pipe. Install a bug screen in the end of the pipe.
- e. Do not locate the vent line terminus near windows, fans, or other ventilation equipment. See the installation instructions furnished with the regulator.
- f. Adhere to all applicable codes and regulations.
- g. If your vent pipe causes regulator pulsation, consult your sales representative or manufacturer.
- h. Itron strongly recommends running a separate vent line for each regulator. Headers with various installed devices can cause regulator malfunction.

Caution Ensure the end of the vent line is away from ANY potential ignition sources. It is the installer's responsibility to ensure the vent line is exhausting to a safe environment.

INSTALLATION

Warning Itron does not endorse or warrant the completeness or accuracy of any third party regulator installation procedures or practices, unless otherwise provided in writing by Itron. Follow your company's standard operating procedures regarding the use of personal protection equipment (PPE). Adhere to guidelines issued by your company in addition to those given in this document when installing regulators.

- a. Remove all shipping plugs from the regulator inlet, outlet, and vent before installation.
- b. Verify the piping interior and regulator inlet and outlet are clean and free of dirt, pipe dope, and other debris. Dirt and other foreign materials entering the regulator can cause a loss of pressure control.
- c. Apply pipe joint sealant to the male pipe threads. Do not use pipe joint material on the regulator's female threads. Joint sealant could become lodged in the regulator and cause a loss of pressure control.
- d. Gas must flow through the regulator's valve body in the direction cast on the regulator body. Gas flowing in the wrong direction can overpressure and cause damage to the regulator.
- e. The pilot diaphragm casing can be mounted in any position relative to the body through a full 360° angle at 90° increments.
- f. When the regulator is installed OUTDOORS, the vent must always be positioned so that rain, snow, moisture or foreign particles cannot enter the vent opening. Itron recommends positioning the pilot vent downward to avoid entry of water or other matter which could interfere with the proper operation of the regulator. The vent should be located away from building eaves, window openings, building air intakes and above the expected snow level at the site. The vent opening should be inspected periodically to insure it does not become blocked by foreign material as outlined in DOT PHMSA-RSPA-2004-19856.
- g. When the regulator is installed INDOORS, the vent must be piped to the outside atmosphere using the shortest length of pipe, the fewest possible pipe elbows, and a pipe diameter as large as the vent size or larger. USING VENT PIPE SMALLER THAN THE VENT CONNECTION LIMITS THE REGULATOR'S INTERNAL RELIEF VALVE CAPACITY. The outlet end of the pipe must be protected from moisture and the entrance of foreign particles. The regulator should be specified by the user with the size vent and pipe threads desired to make the vent pipe connection.

START-UP PROCEDURE

- a. Mount a pressure gauge downstream of the regulator to monitor the downstream pressure.
- b. With the downstream pressure valve closed, slowly open the inlet valve. The outlet pressure should rise to slightly more than the set-point. Verify there are no leaks and all connections are tight.
- c. The regulator was pre-set at the factory to match order specifications. If necessary, adjust the outlet pressure by removing the seal cap on the top of the pilot spring housing and adjusting the ferrule or screw inside the pilot spring housing using a large flat-head screwdriver. With a small amount of gas flowing through the regulator, rotate the pilot ferrule clockwise to raise the outlet pressure or counter-clockwise to lower the outlet pressure.
- d. Replace the seal cap and check for leaks after the desired outlet pressure is achieved.

The regulator is ready for operation.

SAFETY WARNING

This product, as of the date of manufacture, is designed and tested to conform to all governmental and industry safety standards as they may apply to the manufacturer. The purchaser/user of this product must comply with all fire control, building codes, and other safety regulations governing the application, installation, operation, and general use of this regulator to avoid leaking gas hazards resulting from improper installation, startup or use of this product.

Itron strongly recommends installation by a qualified professional and periodic inspection of pressure regulators (inspections may be required by local applicable codes or regulations).

Inspections should include checking for gas quality, cycle numbers, external environmental changes, and operating conditions that impact wear on the regulator's moving parts. To ensure safe and efficient operation of this product, replace worn or damaged parts found during inspection.

LIMITED WARRANTY

Itron, Inc. 2111 North Molter Road Liberty Lake, WA 99019, warrants this gas product against defects in materials and workmanship for the earlier of one (1) year from the date the product is shipped by Itron or a period of one year from the date the product is installed by Itron at the original purchaser's site. During such one-year period, provided that the original purchaser continues to own the product, Itron will, at its sole option, repair any defects, replace the product or repay the purchase price.

» This warranty will be void if the purchaser fails to observe the procedures for installation, operation or service of the product as set forth in the Operating Manual and Specifications for the product or if the defect is caused by tampering, physical abuse or misuse of the product.

- » ITRON SPECIFICALLY DISCLAIMS ALL IMPLIED WARRANTIES INCLUDING THOSE OF MERCHANTABILITY OR OF FITNESS FOR A PARTICULAR PURPOSE. UNDER NO CIRCUMSTANCES WILL ITRON BE LIABLE FOR INCIDENTAL OR CONSEQUENTIAL DAMAGES OF ANY KIND WHATSOEVER.
- » Itron's liability for any claim of any kind, including negligence and breach of warranty for the sale and use of any product covered by or furnished, shall in no case exceed the price allocable to the product or part thereof which gives rise to the claim.
- » In the event of a malfunction of the product, consult your Itron Service Representative or Itron Inc., 2111 North Molter Road Liberty Lake, WA 99019. See Itron Terms and Conditions of Sale for the full and complete terms of the Limited Warranty.

ORDERING INFORMATION

Specify:

1. Inlet and outlet connection size and type
2. Model number
3. Outlet pressure desired
4. Pilot needed
5. Inlet pressure range
6. Type of gas and maximum capacity required
7. Assembly position number (see chart above)
8. Special requirements such as tagging, 1/8" pipe plug tap, seal wire, etc.



Join us in creating a more **resourceful world**.
To learn more visit **itron.com**

CORPORATE HQ

2111 North Molter Road
Liberty Lake, WA 99019 USA

Phone: 1.800.635.5461

Fax: 1.509.891.3355